

E

Calderas de gas

Instrucciones de Funcionamiento,
Limpieza y Mantenimiento
para el **USUARIO**

GB

Gas boilers

Operating, Cleaning
and Maintenance Instructions
for the **USER**

F

Chaudières à gaz

Instructions Fonctionnement
de Nettoyage et de Maintenance
pour l'**USAGER**

D

Gasheizkessel

Betriebs-, Reinigungs-
und Wartungsanleitung
für den **BENUTZER**

I

Caldaie a gas

Istruzioni di Funzionamento
Pulizia e Manutenzione.
per l'**UTENTE**

P

Caldeiras de gás

Instruções de Funcionamento
Limpeza e Manutenção
para o **UTENTE**

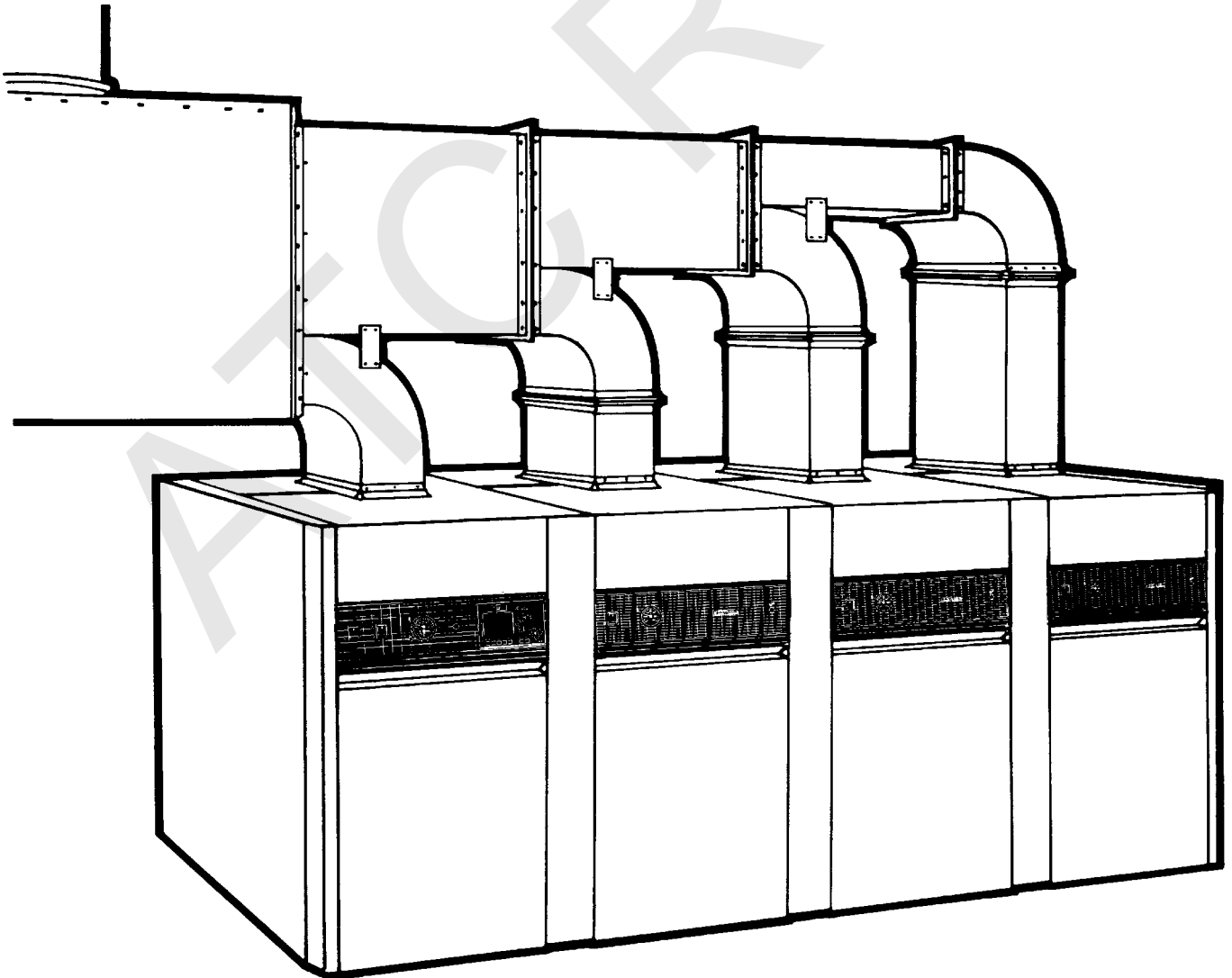
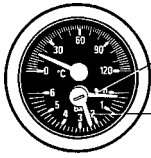

Fig.1



Aguja fija / Fixed pointer
Aiguille fixe / Feststehender Zeiger
Indice fijo / Ponteiro fixo
Aguja móvil / Mobile pointer
Aiguille mobile / Beweglicher Zeiger
Indice mobile / Ponteiro móvel

Fig.2

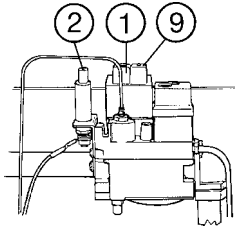

Fig.3

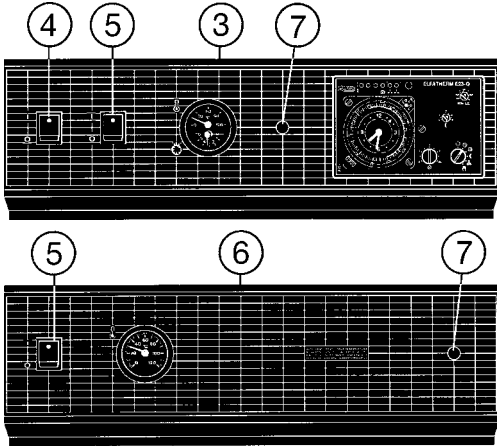

Fig.4

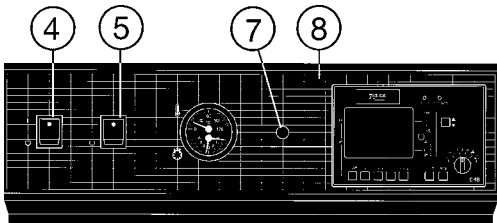

Fig.5

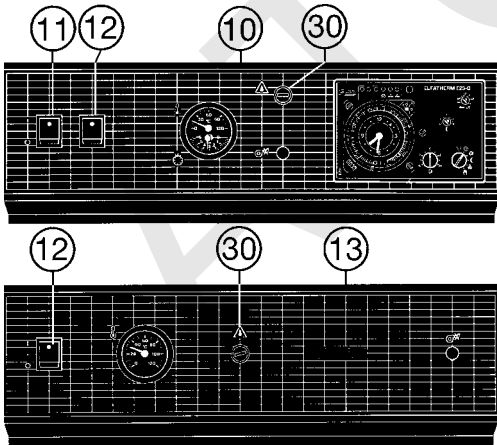

Fig.6

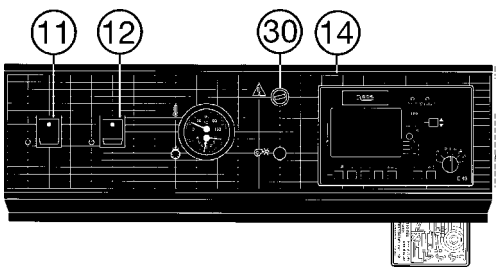

Fig.7

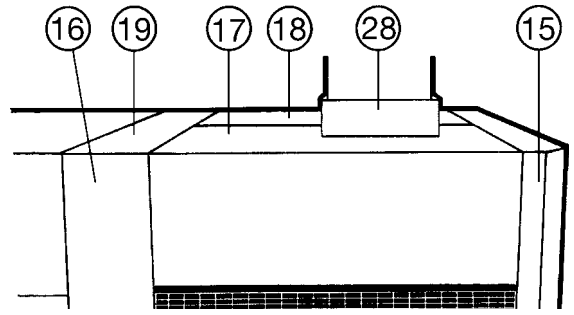

Fig.8

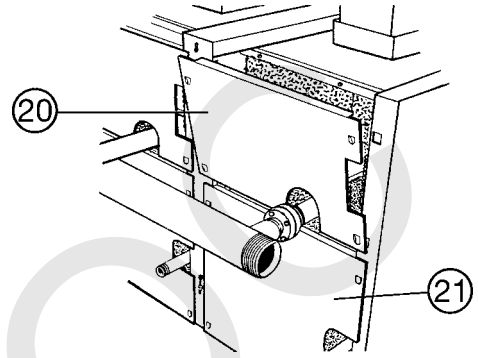

Fig.9

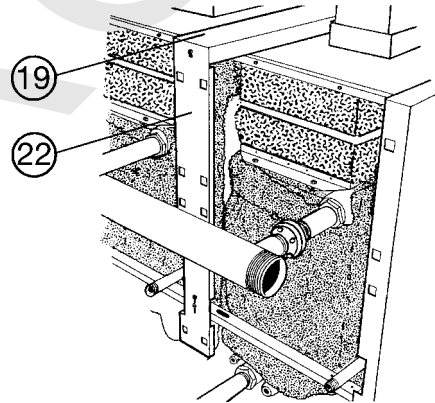

Fig.10

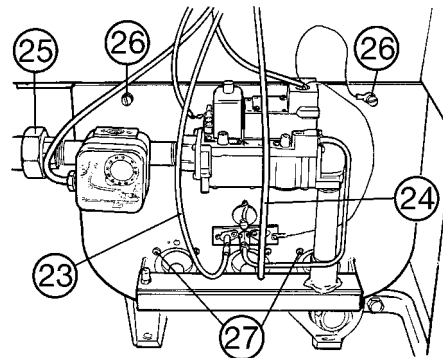
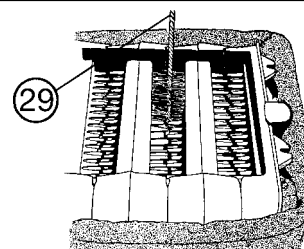

Fig.11



The NG 400 boiler that you have purchased is a top-quality product that will provide you with the service and comfort of central heating that you expect.

The information contained in this document includes the main features of the boiler and the operations which are necessary for its correct performance and maintenance.

Main features

NG 400/IE boilers are not available for town gas.

Boiler model	Nominal heat output		Net efficiency
	kcal/h	kW	%
NG 400/140 & NG 400/140 IE	136.000	158	90,05
NG 400/175 & NG 400/175 IE	174.000	202	90,05
NG 400/215 & NG 400/215 IE	214.000	249	90,05
NG 400/260 & NG 400/260 IE	261.000	303	90,10
NG 400/325 & NG 400/325 IE	321.000	373	90,10
NG 400/425 & NG 400/425 IE	428.000	498	90,15

Max. working temperature: 95°C.

Max. working pressure: 4 bar.

Operation

Checks and operations to follow at the beginning of every heating season, as well as during the boiler's service.

Operations prior to the first lighting

- Check that the installation's flow and return cocks, if there are any, are open.
- Check that the installation is full of water and that the fixed pointer in the Temp/altitude gauge has been placed by the installer in the position which corresponds to the static head of the installation. See Fig. 1.

1 bar = 10 mts.

- Bleed the air in the system and in the radiators.
- In installations with a closed expansion vessel, top up with water (if necessary) until the mobile pointer in the Temp/altitude gauge is slightly above the fixed one. With an open expansion vessel, top up until the mobile pointer levels off with the fixed one.
- Bleed the gas line of each module by loosening the pressure test point screw situated on each gas valve.
- Open the boiler gas valve.
- Please refer to the relevant instructions for the Control Centre.

First lighting of boilers NG 400

- Press the gas valve knob (1) right down in natural or propane gas fired boilers or the relevant knob in models for use with town gas. See Fig. 2.
- Operate the piezoelectric (2).
- Hold the knob (1) down for about 20 seconds so that the pilot flame stays alight.

Boilers NG 400/140, 175 and 215 with control centre

- Operate the main On/off switch (4) and the module switches (5) on the CC-110 (3) and CC-111 (6) control fascias. The indicator lamps (7) on both fascias will light up. See Fig. 3.

Boilers NG 400/260, 325 and 425 with control centre

- Operate the main On/off switch (4) and the module switches (5) on the CC-109 (8) and CC-111 (6) control fascias. The indicator lamps (7) on both fascias will light up. See Fig. 4.

Boilers NG 400 with separate control centre

- Operate the module switches (5) on the CC-111 (6) control fascias.

Note:

Should the pilot flame blow out unexpectedly, wait one minute before lighting again.

Stop

- Press the gas valve knob (9) down in natural and propane gas fired boilers. In town gas fired boilers, close the gas inlet cock for a complete shut-off, otherwise the pilot flame will remain alight. See Fig. 2.
- In order to switch off the boiler while keeping the pilot flame alight, operate the module switch (5) on the control fascias.
- Turn on the main On/off switch (4) or in the case of separate control centres, the switch provided for this purpose.
- Close the boiler gas inlet cock.

First lighting of boilers NG 400/IE

Boilers NG 400/IE 140, 175 and 215 with control centre

- Operate the main On/off switch (11) and the module switches (12) on the CC-126 (10) and CC-127 (13) control fascias. The circulating pump will start running and the gas burners will light up automatically by means of a spark train, with the thermostat in demand position. See Fig. 5.

Boilers NG 400/IE 260, 125 and 425 with control centre

- The contents of the previous paragraph can also be applied to control panels CC-125 (14) and CC-127 (13). See Fig. 6.

Boilers NG 400/IE with separate control centre

- Operate the module switches (12) on each control fascia model CC-127 (13). See Fig. 5.

Stop

- Operate the main On/off switch on the control fascia mod. CC-125 or CC-126 or, if it features a separate control centre, then operate the switch provided for this purpose.

Cleaning

The general cleaning of the boiler must be carried out by specialised personnel whenever necessary, but at least once a year. In this chapter we will point out the most usual operations.

- Switch off the power supply and close the gas inlet cock to the boiler.
- Open the doors, remove the chains and undo the connection between the doors and the left-hand casing panel (1st module on the left) and the right-hand panel (15) or the front cover plate (16) in the other modules. See Fig. 7.

- Remove the top front (17) and back (18) cover plates, press-fitted, after undoing the connection between them and the left-hand panel (1 st module on the left) and the top (19) and front (16) cover plates.
- Detach the top (20) and lower (21) cover plates from the boiler by pulling them upwards. See Fig. 8.
- Remove the back * (22) and top (29) cover plates by pulling them upwards (See Fig. 9), after removing the connection between them and the control panel.

* Separate the electrical wiring from the cable entry clips.

- Remove the front cover plates (16) and the casing side panels after undoing the connection between the left-hand one and the control panel.
- Undo the connection between the connectors situated under the control panel coming from it and from the gas line. In NG 400/IE boilers, also disconnect the ionisation probe (23) and ignition electrode (24) wiring. See Fig. 10.
- Loosen the gas line connector (25) and the screws (26) which fasten the burner support plate. Pull this in order to gain access to the burners and the combustion chamber.
- Remove the screws (27), detach the burners from the support plate and clean them with a brush.
- Remove the flue ducts (28) which rest upon the smoke hoods.
- Undo the fixing nuts and bolts that hold the smoke hoods to each module and these themselves.
- Insert the cleaning brush (29) supplied with the boiler into the smoke passages. See Fig. 11.
- Do the operations in the "Cleaning" section in reverse order.
- Check that the gas lines and the joint between the flue duct and the boiler are airtight with soapy water.

Maintenance

This must be entrusted to specialised personnel. It comprises, at least, the following operations:

- Cleaning the body of the boiler and burners, as described in the previous chapter.
- Measurement and correction, if necessary, of the combustion rates.
- Checking the safety, adjustment and control devices (calibration, tolerance, etc.)
- Cleaning and checking the flue duct.

Important recommendations

In the event of prolonged periods of non-use, the installation must not be emptied.

Water should only be added when topping up is absolutely necessary.

This operation must only be carried out with cold boiler water. Frequent topping up of water may cause lime deposits in the boiler, damage it seriously, and reduce its performance. If the installation is located in a frost-risk area, an antifreeze product should be added to the water in proportion to the minimum outside temperature of the place.

Beware of the risk of burning in case of direct contact with the inspection window or its surrounding area by the flame. Solutions to some malfunctions which may arise after long periods of non-use.

The radiator or panel circuit does not warm up, even when the temperature of the water in the boiler is correct.

Check that:

The pump is rotating correctly.

The valves on each radiator are open and their spindles (headworks) are not jammed.

The burner does not light up: Check that:

The control thermostat on the control panel and the ambient thermostat (if there is one) are set to the right temperature.

The installation fuses are the correct ones and the main switch is ON.

Voltage is reaching the control panel.

- The safety limit thermostat, located in the gas manifold on NG 400 boilers has been activated. To restart the service, repeat the lighting procedure for these boilers.

- The safety limit thermostat in the control panel (30) of NG 400/IE boilers has been activated. Reset it by removing the protection and pressing the button inside. See Fig. 5.

CE Marked

The NG 400 and 400/IE boilers comply with the European Directives 89/336/CEE on Electromagnetic Compatibility, 90/396/CEE on Gas-fired Appliances, and 73/23/CEE on Low Voltage.

Note:

Characteristics and performance qualities subject to change without notice.